

Spark Gap Protectors: SPCD-Leaded Series



Axial Leadwire Type $\Phi 3.1 \times 4.3 \text{mm}$

■ Features

1. Small size
2. RoHS compliant and halogen-free
3. Fast response time
4. Low electrode capacitance (1pF) and high isolation (100M Ω)



■ Recommended Applications

1. Telephone, Fax, Modem
2. Power supplies
3. High frequency signal transmitters/receivers
4. Satellite antenna
5. Radio amplifiers
6. Alarm systems

■ Part Number Code

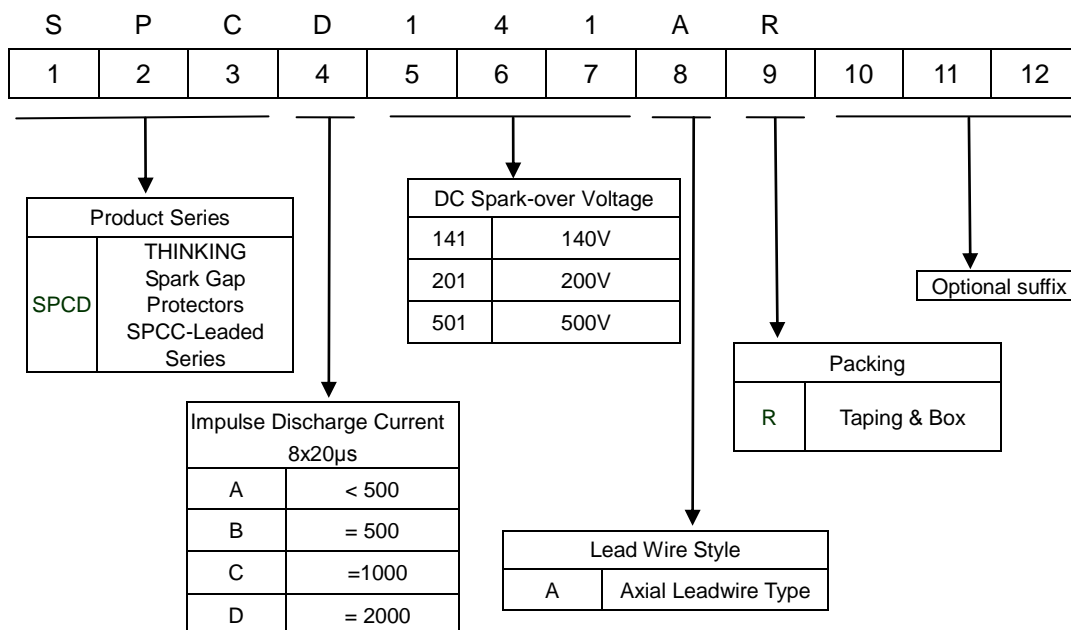

Spark Gap Protectors: SPCD-Leaded Series



Axial Leadwire Type $\Phi 3.1 \times 4.3 \text{mm}$

Structures and Dimensions

SPCD-Leaded Series

Item	Spec	Tolerance
A	$\Phi 3.1$	± 0.2
B	4.3	± 0.5
C	28.5	± 3
D	$\Phi 0.5$	± 0.05

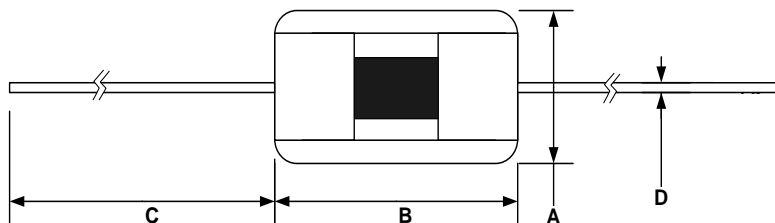

Marking

Color Code

Low-Voltage Series

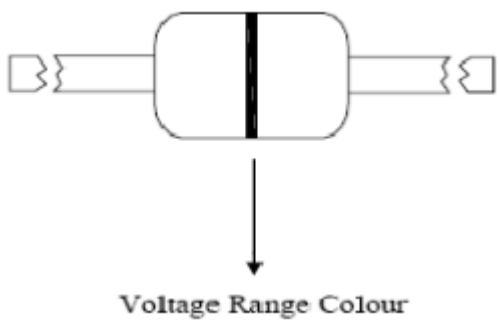

Type	Voltage Range Color
SPCD-141	Gold
SPCD-201	Red
SPCD-301	Orange
SPCD-401	Yellow
SPCD-501	Green

Spark Gap Protectors: SPCD-Leaded Series

Axial Leadwire Type $\Phi 3.1 \times 4.3 \text{mm}$



■ Electrical Characteristics

THINKING Part No.	DC Spark-over Voltage	Impulse Withstanding Voltage Capacity 10x700 μs	Impulse Discharge Current	Min. Insulation Resistance		Max. Capacitance
	100V/S	10x700 μs	8x20 μs	IR	DC	1KHz
	(V)	(KV)	(A)	(M Ω)	(V)	(PF)
SPCD141AR	140 \pm 30%	2	2000	100	50	1.0
SPCD201AR	200 \pm 20%	2	2000	100	100	1.0
SPCD301AR	300 \pm 20%	2	2000	100	100	1.0
SPCD401AR	400 \pm 20%	2	2000	100	250	1.0
SPCD501AR	500 \pm 20%	2	2000	100	250	1.0

Spark Gap Protectors: SPCD-Leaded Series

Axial Leadwire Type $\Phi 3.1 \times 4.3 \text{mm}$



■ Soldering Recommendation

◎ Wave Soldering Profile

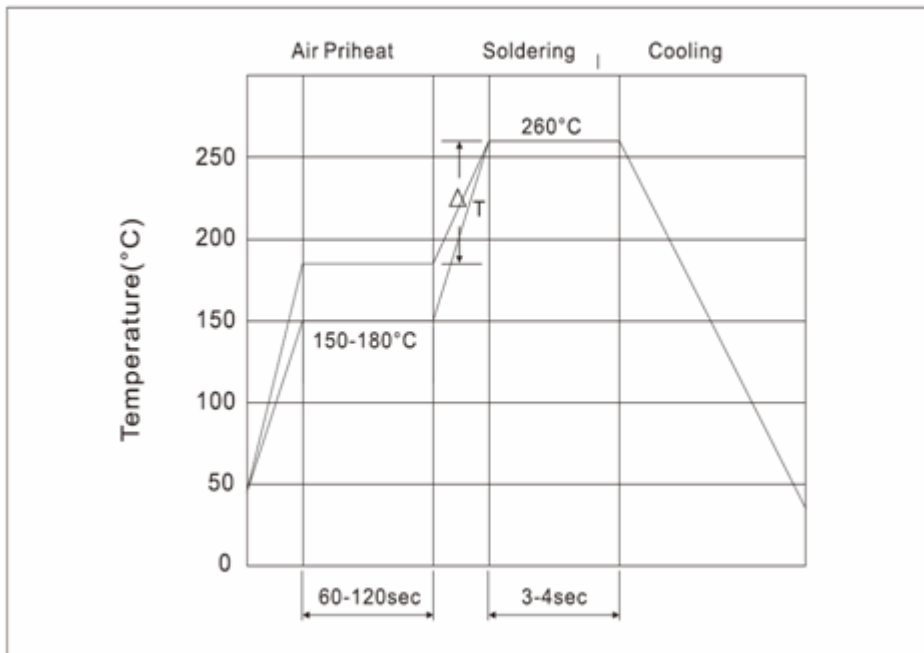

◎ Recommended Reworking Conditions with Soldering Iron :

Item	Conditions
Temperature of Soldering Iron-tip	350±5°C
Soldering Time	3 sec. (max.)

Spark Gap Protectors: SPCD-Leaded Series

Axial Leadwire Type $\Phi 3.1 \times 4.3 \text{mm}$



■ Packaging - Axial Leadwire Type

◎ Reel Taping: 1500pcs / Inner Box

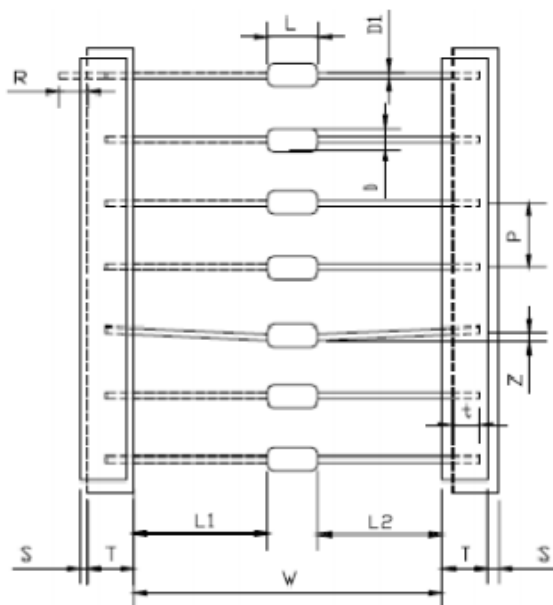

Symbol	Dimension (mm)
W	52±1.5
P	5.0±0.5
L1-L2	1Max
T	6.0±1.0
Z	1.2Max
R	Terminal must not project from tape
t	3.2Max
s	0.8Max
D1	$\Phi 0.5 \pm 0.05$
L	4.8Max

■ Warehouse Storage Conditions of Product

- Storage Condition:
 - 1.Storage Temperature: $-10^{\circ}\text{C} \sim +40^{\circ}\text{C}$
 - 2.Working Temperature: $-40^{\circ}\text{C} \sim +85^{\circ}\text{C}$
 - 3.Keep away from corrosive atmosphere and sunlight.
- Period of Storage: 2 years